

325-L SERIES

Lever Acting Design for 2 psi Piping Systems

Maxitrol's 325-L Series line pressure regulators are for 2 psi piping systems. 325 Series regulators are for use on residential, commercial, and industrial applications.

The 325 Series features a high leverage linkage assembly to deliver positive dead-end lockup. The regulators are capable of precise regulating control from full flow down to pilot flow.



325-3L

Specifications

Pipe Sizes 3/8" to 2" threaded connections with NPT or ISO7-1 threads.

Housing Material 325-3L, 325-5L, 325-7AL, 325-9L: aluminum.

Mounting Suitable for multi-positional mounting. If ball check vent limiting device is installed, mount in an upright position only.

NOTE: All Maxitrol gas pressure regulators should be installed and operated in accordance with Maxitrol Safety Warning Instructions (see GPR_CSA_2PSI_MI_EN.FR).

Certifications 325-3L, 325-5L, 325-7AL, 325-9L: ANSI Z21.80/CSA 6.22 Line Pressure Regulators.

Gas Types Suitable for natural, manufactured, mixed gases, liquefied petroleum gases, and LP gas-air mixtures.

Maximum Inlet Pressure 2 psi (13.8 kPa)

Minimum Inlet Pressure 1 psi (6.9 kPa)

Emergency Exposure Limits 65 psi (450 kPa) (inlet side only)

Maximum Individual Load Largest single appliance served by the regulator: 325-3L: 140,000 Btu/h; 325-5L: 425,000 Btu/h; 325-7AL: 1,250,000 Btu/h; 325-9L: 2,250,000 Btu/h

Capacity Total load of multiple appliance combined
325-3L (3/8", 1/2"): 250,000 Btu/h;
325-5L (1/2"): 500,000 Btu/h; 325-5L (3/4", 1"): 600,000 Btu/h;
325-7AL (1 1/4", 1 1/2"): 1,250,000 Btu/h; 325-9L (1 1/2", 2"): 2,250,000 Btu/h

NOTE: Capacities are used to determine the maximum multiple appliance load. The largest single appliance served by the regulator should not exceed the maximum individual load specified above.

Ambient Temperature Ranges -40 to 205°F (-40 to 96°C)

Minimum Regulation Suitable for pilot flow applications. (P) (Circle P) (0.15 CFH NG).

Imblue Technology™ 325-3L, 325-5L, 325-7AL, 325-9L models may be ordered with Imblue Technology™. Imblue Technology™ increases corrosion resistance and provides extra protection against the elements for regulators used in outdoor applications. Add suffix letter "B" to model number when ordering.

Capacities

Capacities expressed in CFH (m³/h) @ 0.64 sp gr gas

Model	Pipe Size	Outlet Pressure Set Point	Operating Inlet Pressure				
			1/2 psi (3.4 kPa)	3/4 psi (5.2 kPa)	1 psi (6.9 kPa)	1 1/2 psi (10.3 kPa)	2 psi (13.8 kPa)
325-3L	3/8" x 3/8" 1/2" x 1/2"	7.0" w.c. (1.7 kPa)	145 (4.1)	200 (5.7)	250 (7.1)	250 (7.1)	250 (7.1)
		10.0" w.c. (2.5 kPa)	110 (3.1)	180 (5.1)	230 (6.5)	250 (7.1)	250 (7.1)
325-5L	1/2" x 1/2"	7.0" w.c. (1.7 kPa)	360 (10.2)	485 (13.7)	500 (14.2)	500 (14.2)	500 (14.2)
		10.0" w.c. (2.5 kPa)	275 (7.8)	475 (13.5)	500 (14.2)	500 (14.2)	500 (14.2)
325-5L	3/4" x 3/4" 1" x 1"	7.0" w.c. (1.7 kPa)	370 (10.5)	520 (14.7)	600 (17.0)	600 (17.0)	600 (17.0)
		10.0" w.c. (2.5 kPa)	275 (7.8)	450 (12.7)	570 (16.1)	600 (17.0)	600 (17.0)
325-7AL	1 1/4" x 1 1/4" 1 1/2" x 1 1/2"	7.0" w.c. (1.7 kPa)	750 (21.2)	1000 (28.3)	1250 (35.4)	1250 (35.4)	1250 (35.4)
		10.0" w.c. (2.5 kPa)	525 (14.9)	900 (25.5)	1125 (31.9)	1250 (35.4)	1250 (35.4)
325-9L	1 1/2" x 1 1/2" 2" x 2"	7.0" w.c. (1.7 kPa)	1390 (39.4)	2080 (58.9)	2250 (63.7)	2250 (63.7)	2250 (63.7)
		10.0" w.c. (2.5 kPa)	1050 (29.7)	1660 (47.0)	2090 (59.2)	2250 (63.7)	2250 (63.7)

NOTE: See pages 58-59 for Regulator Sizing Requirements and Examples.

Pressure Drop: expressed in CFH (m³/h) @ 0.64 sp gr gas

Model Number	7.0" w.c. (1.7 kPa)	1/2 psi (3.4 kPa)	3/4 psi (5 kPa)
325-3L	145 (4.0)	204 (5.8)	250 (7.0)
325-5L	400 (11.3)	550 (15.6)	670 (19.0)
325-7AL	815 (23.1)	1149 (32.5)	1405 (39.8)
325-9L	1360 (38.5)	2113 (59.8)	2557 (72.4)

Spring Selection

Outlet Pressure Range (all models)

Certified Spring 7" to 11" w.c. (1.7 to 2.7 kPa)

NOTE: See to pages 56-57 for complete Spring Selection Chart.

325-L SERIES

Lever Acting Design for 2 psi Piping Systems

Dimensions

Model	Pipe Size	Vent Connection	Swing Radius	Dimensions		
				A	B	C
325-3L	3/8", 1/2"	1/8" NPT	3" (76 mm)	3.5" (89 mm)	4.2" (108 mm)	3.9" (98 mm)
325-5L	1/2", 3/4", 1"	3/8" NPT	4.9" (124 mm)	5.3" (133 mm)	5.9" (149 mm)	5.4" (138 mm)
325-7AL	1 1/4", 1 1/2"	1/2" NPT	6.1" (156 mm)	7.3" (184 mm)	8" (203 mm)	7" (178 mm)
325-9L	1 1/2", 2"	1/2" NPT	7.8" (198 mm)	9.4" (239 mm)	10.8" (274 mm)	9.1" (231 mm)

NOTE: Dimensions are maximums and to be used only as an aid in designing clearance for the valve.
Actual production dimensions may vary somewhat from those shown.

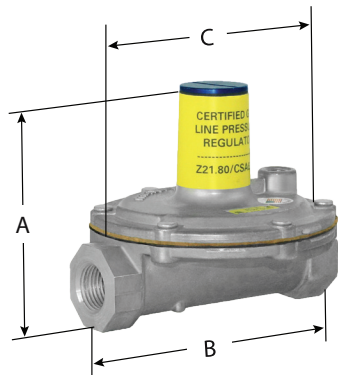

325-3L

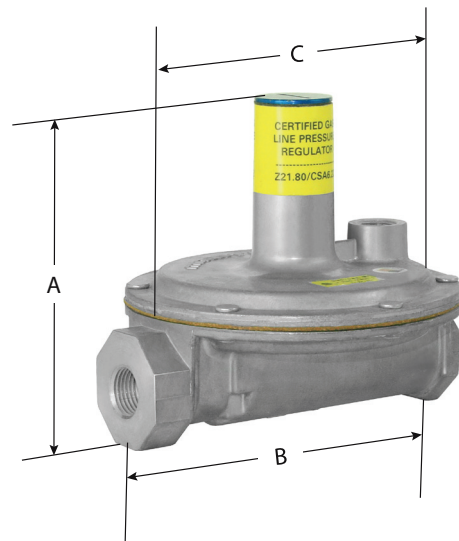

325-5L

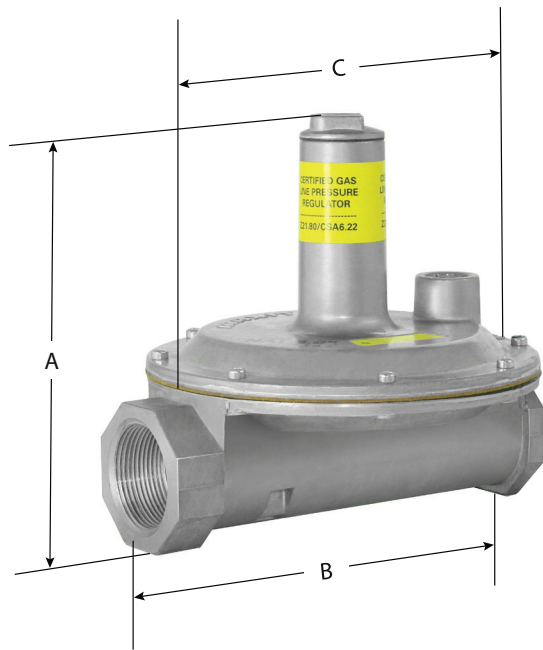

325-7AL

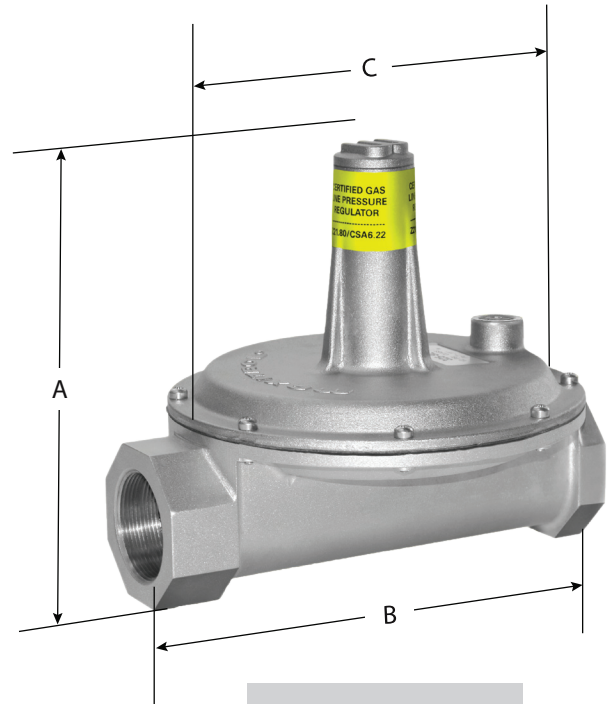

325-9L

Lever Acting Design

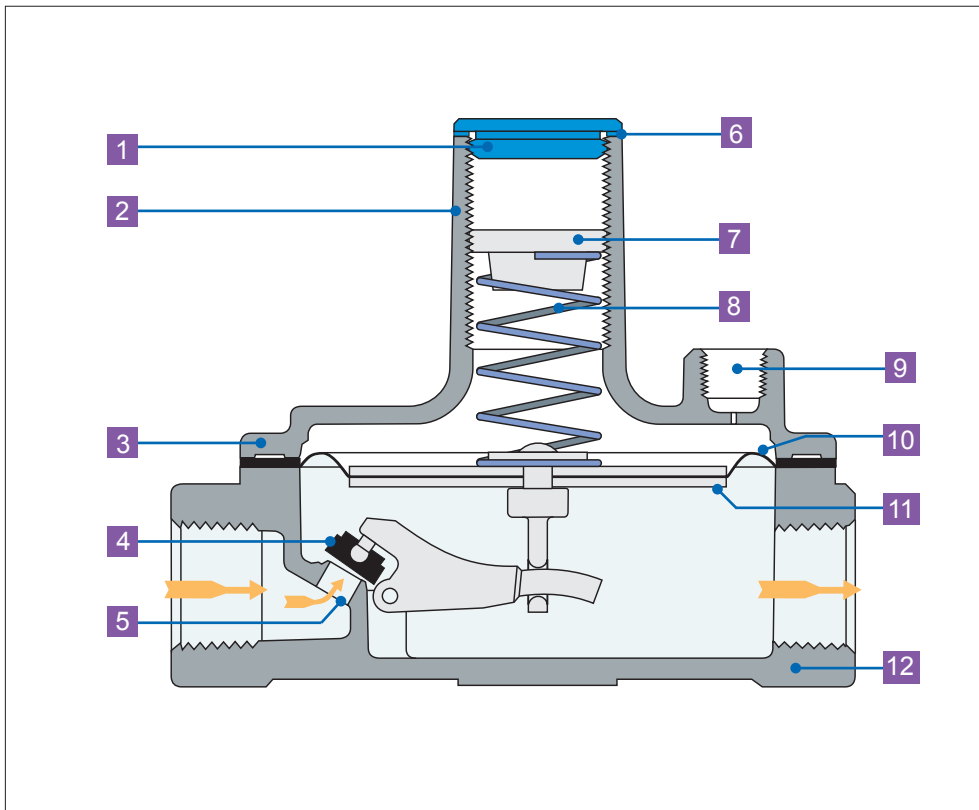

- 1** Seal Cap
- 2** Stack
- 3** Top Housing
- 4** Rubber Valve
- 5** Valve Seat
- 6** Seal Cap Gasket
- 7** Adjusting Screw
- 8** Spring
- 9** Vent Connection
- 10** Diaphragm
- 11** Diaphragm Plates
- 12** Bottom Housing

NOTE: Diagrams are graphical representations only and may differ from actual product.