

Data sheet

Hot gas bypass regulator, type CPCE Liquid gas mixer, type LG (accessory)



CPCE hot gas bypass regulator adapt compressor capacity to actual evaporator load.

They are designed for installation in a bypass line between the low and high pressure sides of the refrigeration system, for hot gas injection between the evaporator and thermostatic expansion valve.

Injection should be arranged to occur through an LG liquid gas mixer.

Features

CPCE hot gas bypass regulator

- Superior control accuracy
- Direct connection to system suction line regulates hot gas injection independent of evaporator pressure drop
- The regulator increases evaporator gas velocity, thus ensuring better oil return to compressor
- Protection against too low an evaporating temperature, i.e. prevents evaporator icing
- May be used in the following EX range: Category 3 (Zone 2)

LG liquid gas mixer

- LG provides homogeneous mixing of the liquid and hot gas refrigerant injected into the evaporator
- Prevents high suction superheat by combining hot gas injection with expansion valve characteristics
- LG can be used for hot gas defrosting or reverse cycle systems

Approvals

UL listed, file SA7200

Technical data

Refrigerants	R22, R1234ze [*]), R1270 [*]), R134a, R290 [*]), R404A, R407A, R407C, R407F, R448A, R449A, R450A, R452A, R507A, R513A, R600 [*]), R600a [*]) [*]) only LG 12-16 and LG 16-22
Regulating range	$p_e = 0 - 6$ bar Factory setting = 0.4 bar
Maximum working pressure	PS/MWP = 28 bar
Maximum test pressure	$P_e = 31$ bar
Maximum differential pressure	$\Delta p = 18$ bar
Maximum media temperature	140 °C
Minimum media temperature	-50 °C

This product is evaluated for R290, R600, R600a, R1234ze, R1270 by ignition source assessment in accordance with standard EN13463-1.

For complete list of approved refrigerants, visit www.products.danfoss.com and search for individual code numbers, where refrigerants are listed as part of technical data.

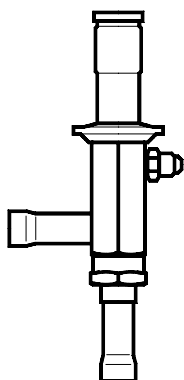
Ordering

Hot gas bypass regulator

Type	Connection				Rated capacity ¹⁾ [kW]				Code no.
	Flare		Solder		R22	R134a	R404A/ R507	R407C	
	[in]	[mm]	[in]	[mm]					
CPCE 12	1/2	12	-	-	17.4	7.9	16.4	19.0	034N0081
CPCE 12	-	-	1/2	12	17.4	7.9	16.4	19.0	034N0082
CPCE 15	-	-	5/8	16	25.6	11.6	24.2	27.9	034N0083
CPCE 22	-	-	7/8	22	34.0	15.2	32.0	37.1	034N0084

¹⁾ The rated capacity is the regulator capacity at:
 - evaporating temperature $t_e = -10$ °C,
 - condensing temperature $t_c = 30$ °C,
 - reduction of suction temperature / suction pressure $\Delta t_s = 4$ K.

Liquid gas mixer

Type	Connection						Code no.
	Outlet ODM		Inlet hot gas ODF		Inlet liquid ODF		
	[in]	[mm]	[in]	[mm]	[in]	[mm]	
LG 12 - 16	5/8	16	1/2	12	5/8	16	069G4001
LG 12 - 22	7/8	22	1/2	12	7/8	22	069G4002
LG 16 - 28	1 1/8	28	5/8	16	1 1/8	28	069G4003
LG 22 - 35	1 3/8	35	7/8	22	1 3/8	35	069G4004

REACH requirements

All Danfoss products fulfill the requirements in REACH.

One of the obligations in REACH is to inform customers about presence of Candidate list substances if any, we hereby inform you about one substance on the candidate list:

an O-ring used in this product contains Diisopentyl phthalate (CAS no: 605-50-5) in a concentration above 0.1% w/w.

Sizing

For optimum performance, it is important to select a CPCE valve according to system conditions and application.

The following data must be used when sizing a CPCE valve:

- Refrigerant: HCFC, HFC and HC
- Minimum suction temperature: t_s in [°C] / [bar]
- Compressor capacity at minimum suction temperature: Q_i in [kW]

- Evaporator load at minimum suction temperature: Q_2 in [kW]
- Liquid temperature ahead of expansion valve: t_l [°C]
- Reduction of suction temperature/suction pressure in [K]
- Connection type: flare or solder
- Connection size in [in] or [mm]

Selection

Example
When selecting the appropriate valve it may be necessary to convert the actual capacity using a correction factor. This is required when system conditions are different from table conditions.

- The following examples illustrate how this is done.
- Refrigerant: R404A
 - Minimum suction temperature: $t_s = -30\text{ }^\circ\text{C}$
 - Compressor capacity at $-30\text{ }^\circ\text{C}$, $Q_1 = 80\text{ kW}$
 - Evaporator load at $-30\text{ }^\circ\text{C}$, $Q_2 = 60\text{ kW}$
 - Liquid temperature ahead of expansion valve: $t_l = 40\text{ }^\circ\text{C}$
 - Reduction of suction temperature/suction pressure = 5 K
 - Connection type: solder
 - Connection size = $\frac{1}{2}$ in

Step 1

Determine the replacement capacity. This is done by taking the compressor capacity at minimum suction temperature Q_1 minus evaporator load at

minimum suction temperature Q_2 .
 $Q_1 - Q_2 = 80 - 60 = 20\text{ kW}$

Step 2

Determine the correction factor for the reduction of suction temperature / suction pressure.

From the correction factor table (see below) a suction temperature reduction of 5 K (R404A) corresponds to a factor of 1.3.

Suction temp. t_s after reduction [°C]	Refrigerant	Suction temperature Δt_s [K]						
		1	2	3	4	5	6	7
10	R134a	0.1	0.5	0.9	1.0	1.0	1.0	1.0
	R22, R404A, R507, R407C	0.3	0.9	1.0	1.0	1.0	1.0	1.0
0	R134a	0.1	0.3	0.7	1.0	1.0	1.0	1.0
	R22, R404A, R507, R407C	0.2	0.9	1.0	1.0	1.0	1.0	1.0
-10	R134a	0.1	0.3	0.6	1.0	1.3	1.4	1.4
	R22, R404A, R507, R407C	0.1	0.5	1.0	1.0	1.0	1.0	1.0
-20	R134a	0.1	0.3	0.6	1.0	1.5	2.2	2.4
	R22, R404A, R507, R407C	0.1	0.3	0.7	1.0	1.0	1.0	1.0
-30	R134a	0.1	0.3	0.6	1.0	1.5	2.2	2.9
	R22, R404A, R507, R407C	0.1	0.3	0.6	1.0	1.3	1.4	1.4
-40	R22, R404A, R507, R407C	0.1	0.3	0.6	1.0	1.5	2.0	2.2

The correction table is used when suction temperature change deviates from 4 K.

The replacement capacity must be divided by the correction factor determined.

Step 3

Corrected replacement capacity is
 $Q = 20 / 1.3 = 15.4\text{ kW}$

Step 4

Now select the appropriate capacity table for R404A and choose the column with a suction temperature of $t_s = -30\text{ }^\circ\text{C}$.

Using the corrected replacement capacity, select a valve that provides an equivalent or greater capacity.
A CPCE 12 delivers a replacement capacity of 17.9 kW at a minimum suction temperature of $-30\text{ }^\circ\text{C}$.

Step 5

CPCE 12, $\frac{1}{2}$ in solder connection, code no. **034N0082** (see Ordering).

Capacity

Type	Suction temperature t_s after pressure / temperature reduction [°C]	Regulator capacity Q [kW] at condensing temperature t_c [°C]				
		20	30	40	50	60
R22						
CPCE 12	10	7.9	16.3	21.6	26.9	33.4
	0	12.9	17.3	21.7	27.1	33.4
	-10	13.6	17.4	22.0	27.4	33.4
	-20	13.7	17.6	22.2	27.7	33.4
	-30	8.0	11.0	14.7	18.6	33.4
	-40	4.3	5.7	7.6	–	33.4
CPCE 15	10	11.5	24.0	31.7	39.4	49.0
	0	18.8	25.4	32.0	39.9	49.0
	-10	20.0	25.6	32.3	40.2	49.0
	-20	20.1	25.8	32.6	40.7	49.0
	-30	11.5	16.0	21.2	27.1	49.0
	-40	5.9	7.8	10.6	–	49.0
CPCE 22	10	15.2	31.7	42.0	52.3	64.9
	0	25.0	33.6	42.4	52.8	64.9
	-10	26.5	34.0	42.8	53.4	64.9
	-20	26.6	34.2	43.1	53.8	64.9
	-30	15.4	21.3	28.1	35.9	64.9
	-40	8.0	10.7	14.3	–	64.9
R134a						
CPCE 12	10	2.3	10.4	14.4	18.0	22.6
	0	7.8	11.3	14.4	18.1	22.6
	-10	5.8	7.9	10.8	14.4	18.1
	-20	3.4	4.6	6.1	8.3	10.6
	-30	2.0	2.8	3.7	4.9	6.2
CPCE 15	10	2.3	15.2	21.1	26.5	33.2
	0	11.4	16.6	21.2	26.6	33.2
	-10	8.3	11.6	15.7	21.1	26.6
	-20	4.8	6.6	8.8	11.9	15.2
	-30	2.6	3.5	4.9	6.4	8.0
CPCE 22	10	3.1	20.4	28.0	35.2	43.9
	0	15.1	22.8	28.1	35.2	43.9
	-10	10.9	15.2	20.9	27.7	35.2
	-20	6.4	8.8	11.8	15.7	20.3
	-30	3.7	5.0	6.8	8.9	11.3

The capacities are determined by reducing the suction temperature/suction pressure at $\Delta t_s = 4$ K. The given suction temperatures are minimum values, i.e. after reduction.

The capacities are made up of the CPCE hot gas capacity + the extra capacity given by the thermostatic expansion valve to keep the superheat constant after the evaporator.

Data sheet | Hot gas bypass regulator type CPCE, Liquid gas mixer type LG (accessory)

Capacity
(continued)

Type	Suction temperature t_s after pressure / temperature reduction [°C]	Regulator capacity Q [kW] at condensing temperature t_c [°C]				
		20	30	40	50	60
R404A/R507						
CPCE 12	10	7.5	15.5	20.6	25.7	31.1
	0	12.2	16.4	20.6	25.7	31.1
	-10	12.9	16.4	20.7	25.7	31.1
	-20	13.1	16.4	20.7	–	31.1
	-30	10.3	13.8	17.9	–	31.1
	-40	5.5	7.5	9.5	–	31.1
CPCE 15	10	11.0	22.8	30.3	37.8	46.9
	0	18.0	24.2	30.3	37.8	46.9
	-10	19.1	24.2	30.4	37.8	46.9
	-20	19.1	24.3	30.4	–	46.9
	-30	15.0	20.3	26.5	–	46.9
	-40	8.0	10.6	13.4	–	46.9
CPCE 22	10	14.6	30.2	40.1	49.9	62.3
	0	23.8	32.0	40.1	49.9	62.3
	-10	25.3	32.0	40.1	50.0	62.3
	-20	25.3	32.1	40.2	–	62.3
	-30	19.9	26.7	34.8	–	62.3
	-40	10.6	14.2	18.0	–	62.3
R407C						
CPCE 12	10	9.7	18.3	23.5	28.2	33.4
	0	14.4	19.0	23.2	27.9	33.4
	-10	15.1	19.0	23.3	27.4	33.4
	-20	15.1	18.8	23.1	27.4	33.4
	-30	8.7	11.7	15.0	18.0	33.4
	-40	4.6	5.9	7.6	–	33.4
CPCE 15	10	14.1	26.9	34.6	41.4	49.0
	0	21.1	27.9	34.2	41.1	49.0
	-10	22.2	27.9	34.2	40.2	49.0
	-20	22.1	27.6	33.9	40.3	49.0
	-30	12.5	17.0	21.6	26.3	49.0
	-40	6.3	8.1	10.6	–	49.0
CPCE 22	10	18.7	35.5	45.8	54.9	64.9
	0	28.0	37.0	45.4	54.4	64.9
	-10	29.4	37.1	45.4	53.4	64.9
	-20	29.3	36.6	44.8	53.3	64.9
	-30	16.8	22.6	28.7	34.8	64.9
	-40	8.6	11.1	14.3	–	64.9

The capacities are determined by reducing the suction temperature/suction pressure at $\Delta t_s = 4$ K. The given suction temperatures are minimum values, i.e. after reduction.

The capacities are made up of the CPCE hot gas capacity + the extra capacity given by the thermostatic expansion valve to maintain the superheat after of the evaporator constant.

Design / Function

CPCE

- 1. Inlet
- 2. Outlet
- 3. Pilot pressure connection
- 4. Protective cap
- 5. Setting screw
- 6. Main spring
- 7. Diaphragm
- 8. Pressure pin
- 9. Pilot orifice
- 10. Servo piston
- 11. Pressure equalising hole
- 12. Main orifice

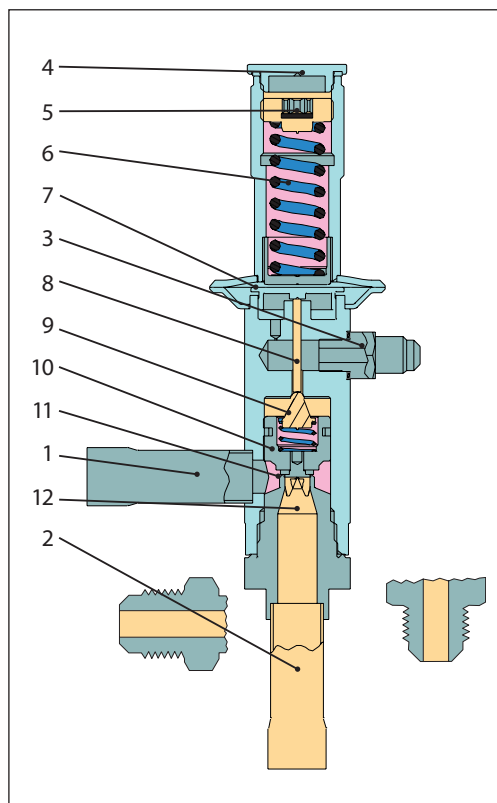

Hot gas bypass regulator, type CPCE is servo-operated. The diaphragm (7) is actuated on the upper side by the force developed by the spring (6) and on the lower side by the pilot pressure from (3). When the pilot pressure drops below the preset value, the throttling ball is forced away from the pilot orifice (9) by the spring which acts via the pressure pin (8). The pressure over the servo piston (10) is then relieved. The differential pressure which is thus created moves the servo piston up and causes the regulator to open so that hot gas is able to flow to the suction side. When the pilot pressure rises above the setting, the pilot orifice shuts off the evacuation from the space over the servo piston. Pressure then builds up again over the piston via the pressure equalising hole (11), thus closing the regulator.

LG

- 1. Liquid inlet
- 2. Hot gas inlet
- 3. Outlet

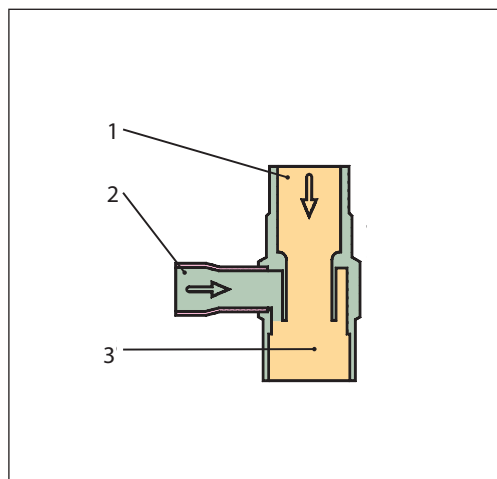

Dimensions [mm]
and weights [kg]

CPCE

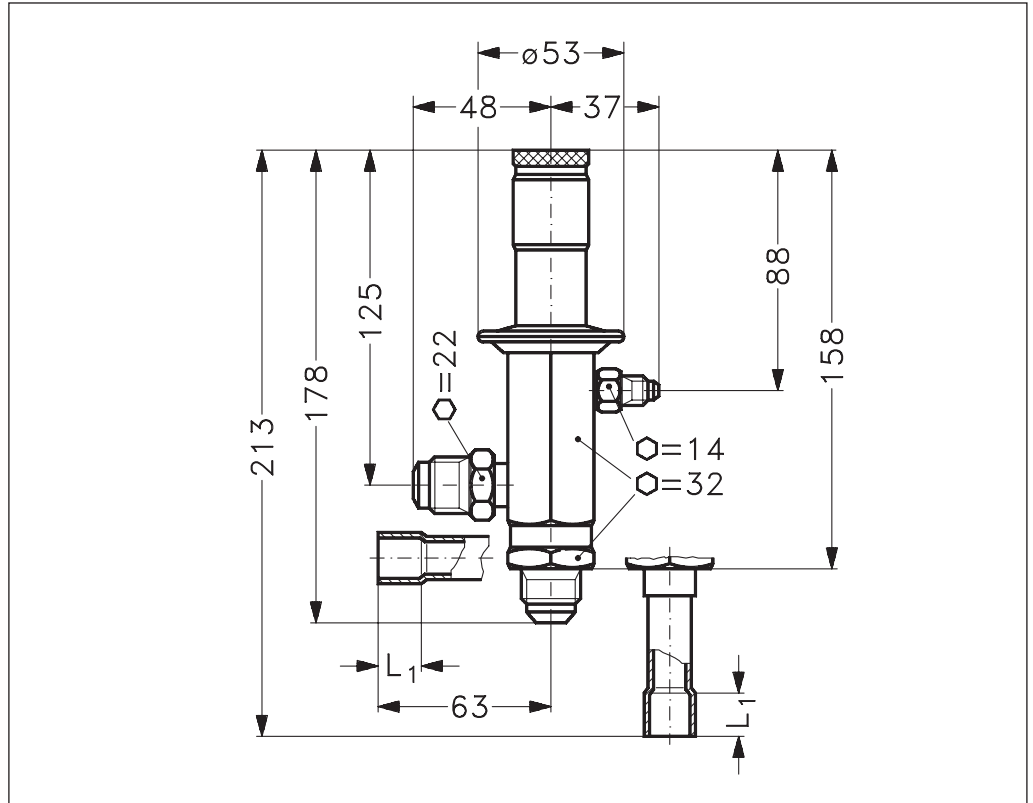

Type	L ₁	Net weight
CPCE 12	10	0.9
CPCE 15	12	0.9
CPCE 22	17	0.9

LG

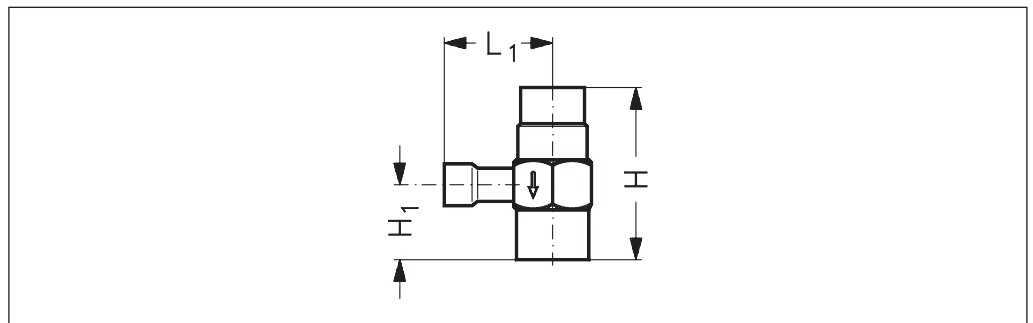

Type	H	H ₁	L ₁	NV	Net weight
LG 12 – 16	54	22	40	24	0.1
LG 12 – 22	62	26	42	28	0.2
LG 16 – 28	79	35	48	36	0.3
LG 22 – 35	89	40	66	41	0.4

Danfoss can accept no responsibility for possible errors in catalogues, brochures and other printed material. Danfoss reserves the right to alter its products without notice. This also applies to products already on order provided that such alterations can be made without consequential changes being necessary in specifications already agreed. All trademarks in this material are property of the respective companies. Danfoss and the Danfoss logotype are trademarks of Danfoss A/S. All rights reserved.