

Installation guide

Hot gas bypass regulator type CPCE

Liquid gas mixer type LG (accessory)

034R9507

034R9507

CPCE Refrigerants:

R22, R1270, R134a, R290, R404A, R407A, R407C, R407F, R448A, R449A, R450A, R452A, R507A, R513A, R600, R600a

For complete list of approved refrigerants, visit www.products.danfoss.com and search for individual code numbers, where refrigerants are listed as part of technical data.

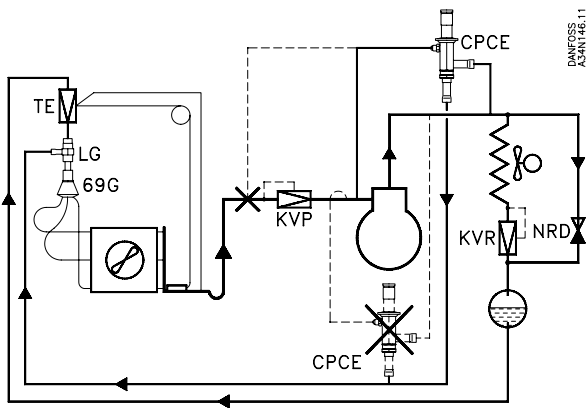
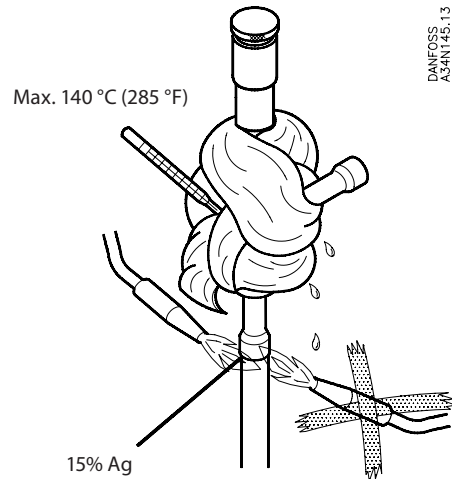
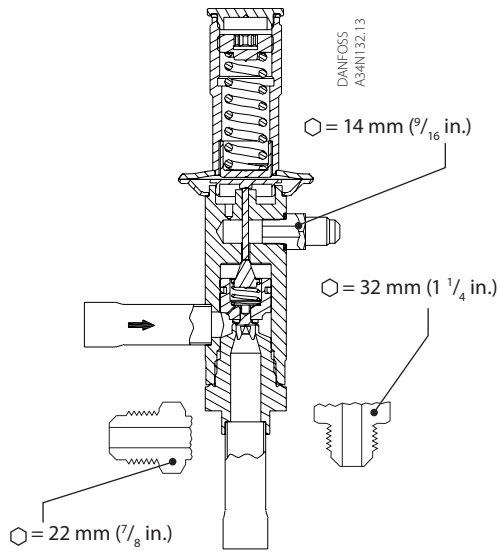
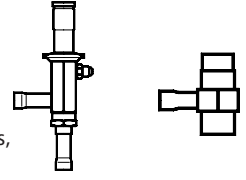

$t_{max.} = 140\text{ °C (285 °F)}$
 $t_{min.} = -50\text{ °C (-60 °F)}$

PS/MWP = 28 bar p_e (405 psig)
 $P_{max. test} = 31\text{ bar } p_e$ (450 psig)

NB! Tightening torque must be respected especially when used with flammable refrigerants

4Nm (finger tight + 1/4 turn)

